



TEREX

TH1048C

Telehandler

OPERATING WEIGHT	30,200 lbs (13,696 kg)
NET ENGINE POWER	115 hp (85.8 kW)
MAXIMUM LIFT CAPACITY	10,000 lbs (4,536 kg)
MAXIMUM LIFT HEIGHT	48' (14.6 m)



TELEHANDLER TH1048C

Specifications

Performance

Operating weight with forks	30,200 lbs (13,696 kg)
Inside/outside turn radius	6' 8" / 15' 2" (2.03 / 4.62 m)
Maximum lifting height	48' (14.6 m)
Reach at maximum height	5' 6" (1.68 m)
Maximum forward reach	31' (9.45 m)
Maximum lift capacity	10,000 lbs (4,536 kg)
Payload at maximum height	6,000 lbs (2,721 kg)
Payload at maximum reach	3,000 lbs (1,360 kg)

Steering

Power assisted steering

Three steering modes: 2-wheel, 4-wheel coordinated, and 4-wheel crab

Engine

John Deere 4045T	
4 cylinders turbocharged diesel	
Power @ 2,500 rpm	115 hp (85.8 kW)
Tier II Compliant	

Transmission

3 Speed Powershift/Torque Converter	
4 wheel drive	
Front axle differential lock	
Maximum speed	18.5 mph (29.8 km/h)

Brakes

Inboard multiple wet disc

Telehandler TH1048C

Specifications

Sway Control - Frame Leveling

Circuit isolated cylinders, 10 degrees either side of center

Frame Stabilizer

Twin rear axle lock cylinders

Hydraulic System

Pressure compensated hydraulic system

Variable-displacement axial piston pump

10 Micron filtration

Tank Capacities

Fuel 30 gal (113.6 L)

Hydraulic oil 48 gal (181.7 L)

Tires

1400 x 24-12 ply, calcium chloride solution filled

Forks and Attachment Holder Plate

Length 48" (1,200 mm)

Section 5" x 2.25" (127 mm x 57 mm)

Operating Cab

Structure conforms to ISO 8471 (ROPS) and ISO 8449 (FOPS)

Optional enclosed cab, heater and air conditioning

Attachments and Fork Options

Cubing tines

Pallet forks 60" & 72" (1.52 & 1.83 m)

Rotating fork frames 48", 60", & 72" (1.22, 1.52, & 1.83 m)

45° Swing fork frames 60" & 72" (1.52 & 1.83 m)

Rubbish bucket 1 yd³ (0.76 m³)

Variable reach truss boom

Quick switch attachment

Auxiliary hydraulic circuit

Dimensions with Boom Retracted and Down

Overall L x W x H 26' 6" x 8' 6" x 9' 7" (8.08 x 2.59 x 2.92 m)

Wheelbase 11' 3" (3.43 m)

Turning radius (outside tire) 15' 2" (4.62 m)

Ground clearance 1' 7" (.48 m)

Working Ranges and Lift Capacities

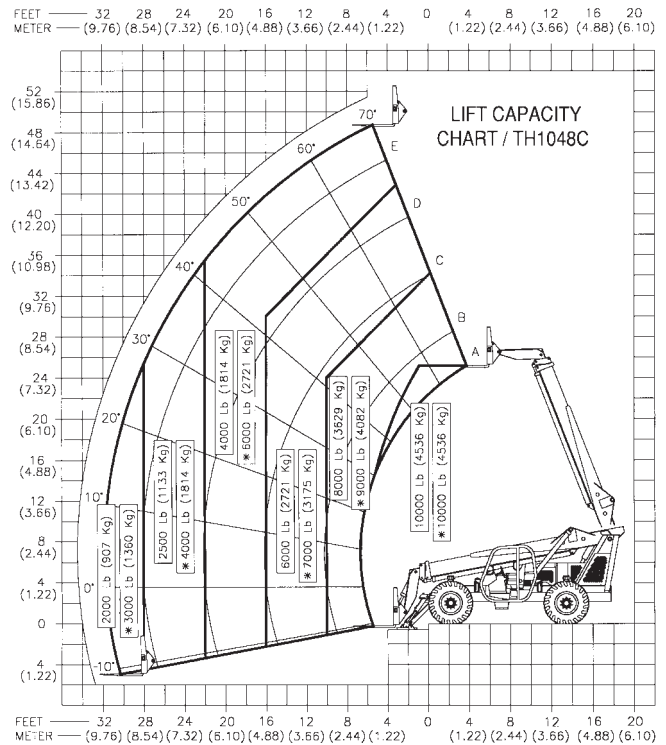

Genie Industries, Inc.

18340 NE 76th Street
PO Box 97030
Redmond, WA 98073-9730

TEL 425-881-1800
TOLL FREE 800-536-1800
PARTS & TECH SUPPORT 888-201-6008
FAX 425-883-8475
WEB terex.com
genieindustries.com

For more information, product demonstration, or details on purchase, lease and rental plans, please contact your local TEREX Distributor.